

► Our technology. Your success.

Pumps • Valves • Service

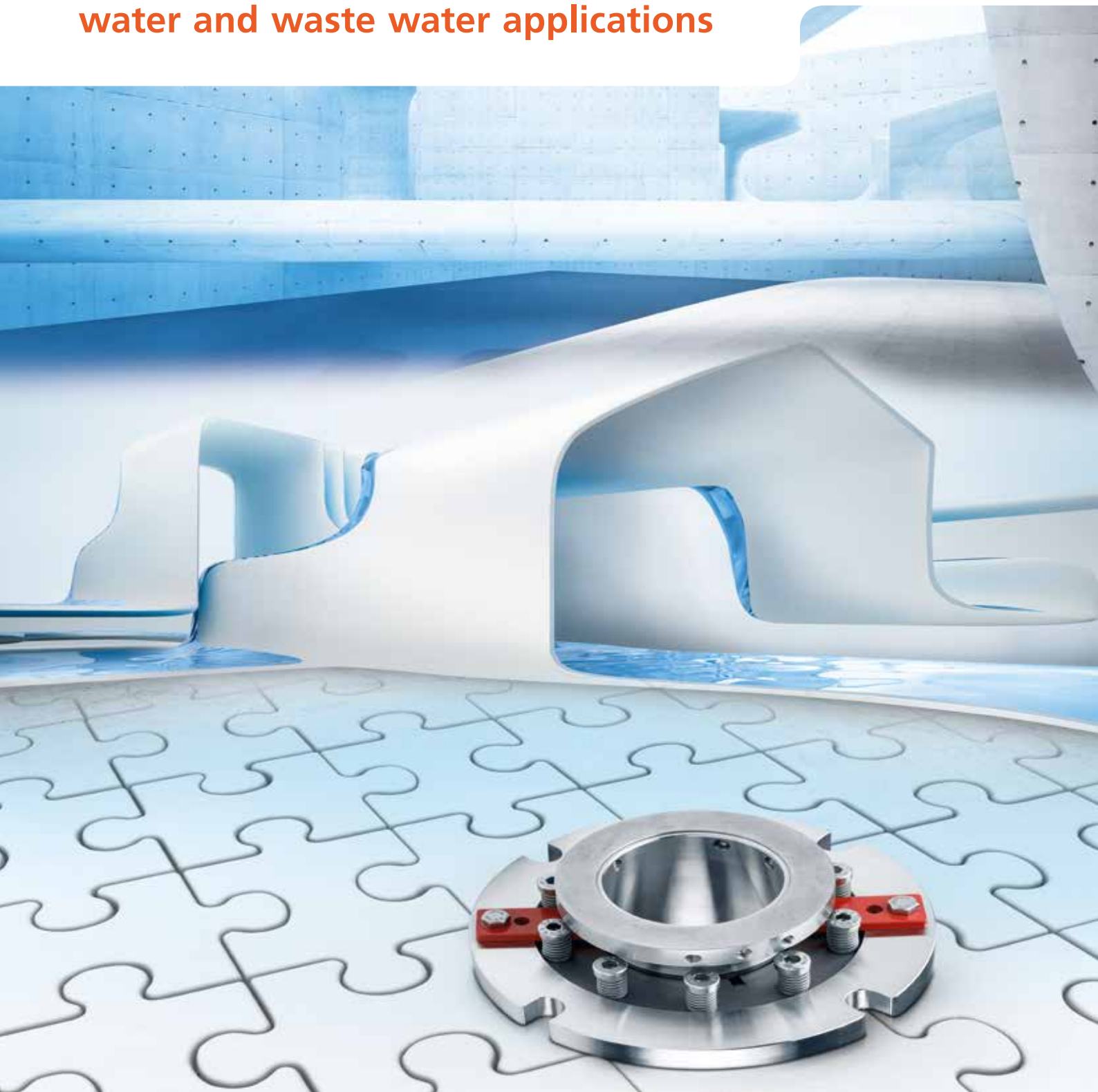

KSB mechanical seals for water and waste water applications



Single-source supplier: your partner for pumps, valves and service

We are your partner for the entire product life cycle. Customised service solutions, short response times and an extensive product portfolio – no other competitor offers a comparable range of products and services.



From initial consultancy to planning, installation, operation, maintenance and comprehensive service concepts, we are on hand as your reliable partner to provide solutions for every situation and requirement – over the entire product life cycle. We offer service and spare parts solutions as part of our comprehensive customer care – not only for KSB pumps and valves but also for all sorts of rotating equipment of all makes.

KSB mechanical seals

KSB's range of tailored spare parts services plays a major role in the service portfolio. This includes KSB mechanical seals. As well as impressing with a robust design, they offer service-friendly installation and optimal integration in the seal chamber. Tried and tested quality.



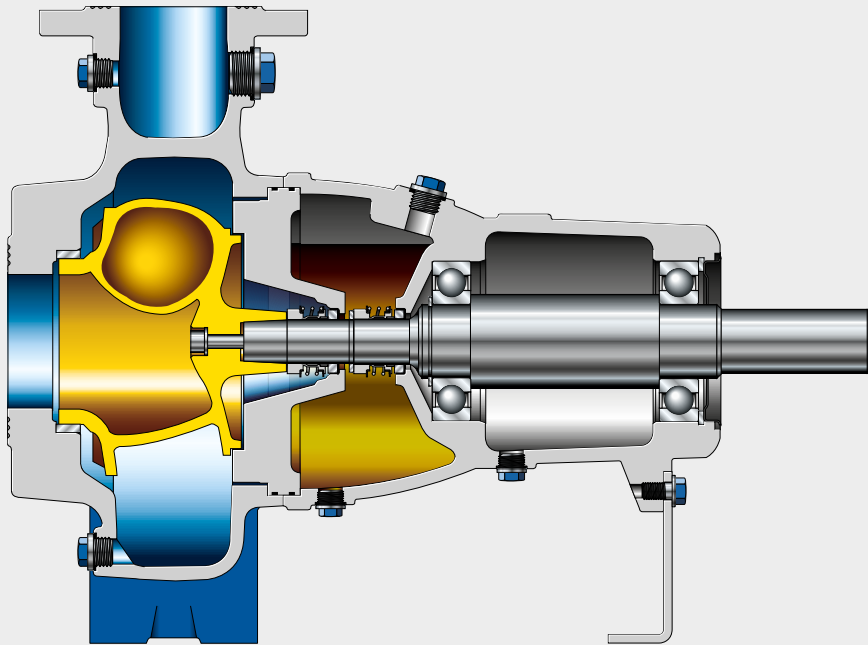

4STQ mechanical seal for Sewatec/Sewabloc and Amarex KRT

The Sewatec and Amarex KRT pump type series for waste water transport and sludge treatment are optimally sealed by KSB's 4STQ mechanical seal. With its pump-optimised design this seal has been approved for all of the pump's applications. Its springs, located in an oil reservoir outside the fluid handled, are insensitive to contamination; they provide uniform surface

pressure across the contact faces, thus ensuring a long service life. The balanced double KSB mechanical seal in tandem arrangement brings the additional benefit of a modular design. Optimum pre-loading of the mechanical seal is taken care of as the seal is easy to install without adjusting dimensions and assembly fixtures.



4STQ for Sewatec/Sewabloc

Design	Double cartridge seal
Type	Stationary, balanced
Springs	Multi-spring arrangement
Operating pressure	Up to 10 bar dynamic, up to 16 bar static
Temperature	0 °C to 70 °C
Bearing bracket (seal size)	S01 (022/025), S02 (033/033), S03 (033/055), S05 (065/065), S08 (120/120), S09 (150/150),
Business type	Engineered

4STQ for Amarex KRT

Design	Double cartridge seal
Type	Stationary, balanced
Springs	Multi-spring arrangement
Operating pressure	Up to 10 bar dynamic, up to 16 bar static
Temperature	0 °C to 70 °C
Bearing bracket (seal size)	S01 (022/025), S02 (033/033), S03 (033/055)
Business type	Standard (KSB EasySelect)

Tailored sealing solutions for the KWP pump type series

All applications of KSB's KWP pump type series can be matched with a KSB mechanical seal. The 4K single and 4KD double KSB engineered seals and the 4KDC double cartridge seal have a stationary design with the springs arranged outside the fluid handled. They are thus ideal for waste water applications with high solids contents. The 4KBL direct retrofit seal is the match for KWP-Bloc pumps. For sealing waste water with a very high solids content, such as in flue gas desulphurisation, KWP (FGD) pumps are combined with a 4K cartridge seal.

4K for KWP



This single mechanical seal is tailored to the seal installation space of the pump. Its large external springs are insensitive to contamination and provide uniform surface pressure across the contact faces, thus ensuring a long service life. Optionally, this seal is available as a 4KD double seal.

Design	Single* mechanical seal
Type	Stationary, balanced
Operating pressure	Up to 25 bar dynamic Up to 37.5 bar static
Temperature	-20 °C to 150 °C

* Also available as a double mechanical seal

4K Cartridge for KWP (FGD)

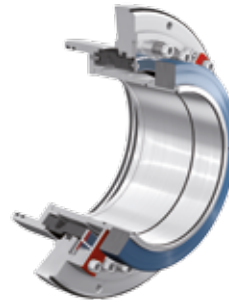

This single cartridge seal is designed specially for applications with high solids contents. Optionally, a system for periodic flushing can be connected to flush away leakage products and significantly extend the seal life.

Design	Single cartridge seal
Type	Stationary, balanced
Operating pressure	Up to 10 bar dynamic Up to 15 bar static
Temperature	-10 °C to 110 °C

4KBL for KWP-Bloc

This single mechanical seal includes the shaft protecting sleeve for the pump to facilitate installation. This means no axial adjusting dimension is required, and the mechanical seal is always perfectly positioned on the shaft.

Design	Single mechanical seal
Type	Dynamic, balanced
Operating pressure	Up to 25 bar dynamic Up to 37.5 bar static
Temperature	0 °C to 100 °C





4KDC for KWP

This double cartridge seal includes the shaft protecting sleeve for the pump and can be used to replace competitor seals without any modifications. Given the stationary design the springs are located outside the fluid handled and thus protected from contamination. Optimum heat dissipation in the seal area is provided by the pumping screw. The circulation system circulates the buffer/barrier fluid effectively and, consequently, increases the seal life. The double mechanical seal's cartridge can be operated both with unpressurised buffer fluid (quench) and with pressurised barrier fluid.



Design	Double cartridge seal
Type	Stationary, balanced
Operating pressure	13 to 25 bar dynamic, depending on the size
Temperature	-5 °C to 160 °C

KSB direct retrofit seals and standardised seals for clean, raw and service water applications

For sealing KSB's RDLO and Omega pump type series, KSB offers the pump-specific direct retrofit seals 4RD and 4OM. The Multitec pump type series is covered by KSB's 5B standardised seal, which can be installed in all pumps with standardised installation spaces to EN 12756. Also, all seals are WRAS-approved for drinking water.

4OM for Omega



This robust and practical seal covers all applications of the Omega pump. The single mechanical seal includes the spacer sleeve for the pump, so it can be fitted without requiring an adjusting dimension.

Design	Single mechanical seal
Type	Dynamic, balanced
Operating pressure	Up to 25 bar dynamic Up to 37.5 bar static
Temperature	-10 °C to 140 °C

4RD for RDLO

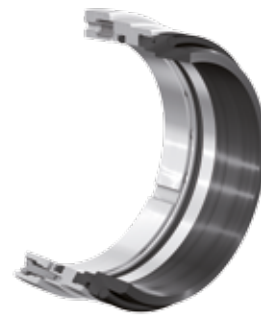

Together with the shaft protecting sleeve of the pump, the 4RD seal can be installed like a cartridge. The primary ring is shrink-fitted into the metal primary ring carrier. This ensures even contact, also under fluctuating pressure and temperature conditions.

Design	Single mechanical seal
Type	Dynamic, balanced
Operating pressure	Up to 25 bar dynamic Up to 37.5 bar static
Temperature	0 °C to 140 °C

5B for all KSB pump type series with a standardised seal to EN 12756

Installing this standardised seal to EN 12756 is greatly facilitated by a circlip holding together the dynamic unit. The seal can be used for a large variety of applications, also with a quench system or as a double seal in back-to-back arrangement.

Design	Single mechanical seal
Type	Dynamic, balanced
Operating pressure	Up to 25 bar dynamic Up to 37.5 bar static
Temperature	-30 °C to 220 °C



Seawater applications: pump-optimised KSB engineered seals for a long service life

Seawater places exacting demands on all pump components, including the mechanical seal.

The two cartridge seals 4Spider and 4UM are used for KSB's UMA submersible motor. Even in tough external conditions these seals are easy to install and remove as no adjusting dimension is necessary for the installation. The spring travel accommodates for the technical requirements of the motor shaft and thrust bearing. Depending on the size, the sleeve of the mechanical seal also houses the connection between coupling and pump, thus keeping the shaft dry. Seawater

desalination applications are covered by KSB's pump series HGM-RO and RPH-RO. The 4HG mechanical seal matches the HGM-RO pump type series. It includes the shaft protecting sleeve of the pump and is easy to install thanks to its modular design. For the RPH-RO pump KSB offers its 4RPS single cartridge seal. The seal's materials and design ensure a long service life and are perfectly matched to the pump application.

4Spider for UMA/UPA



Design	Single cartridge seal
Type	Stationary, balanced
Operating pressure	Up to 20 bar dynamic Up to 30 bar static
Temperature	0 °C to 80 °C

4HG for HGM-RO



Design	Single mechanical seal
Type	Dynamic, balanced
Operating pressure	Up to 6 bar dynamic Up to 25 bar static
Temperature	0 °C to 70 °C

4UM for UMA/UPA



Design	Single cartridge seal
Type	Stationary, balanced
Operating pressure	Up to 20 bar dynamic Up to 30 bar static
Temperature	0 °C to 110 °C

4RPS for RPH-RO



Design	Single cartridge seal
Type	Stationary, balanced
Operating pressure	Up to 70 bar dynamic Up to 100 bar static
Temperature	0 °C to 80 °C



Technology that **makes its mark**

The KSB Newsletter –
don't miss out, sign up now:
www.ksb.com/newsletter



Your local KSB representative:



KSB Aktiengesellschaft
Johann-Klein-Straße 9
67227 Frankenthal (Germany)
www.ksb.com

You can also visit us at
www.ksb.com/socialmedia