

KSB Mechanical Seal

4CP

for the MegaCPK Type Series

Supplementary Operating Manual

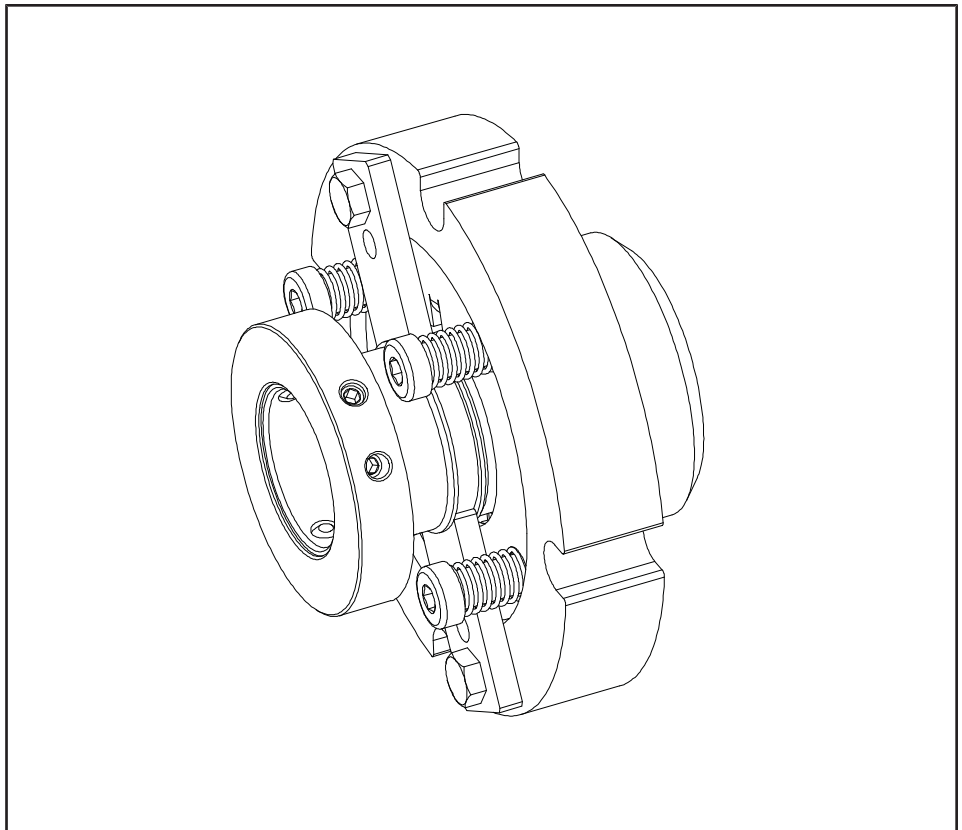

Legal information/Copyright

Supplementary Operating Manual 4CP

Original operating manual

All rights reserved. The contents provided herein must neither be distributed, copied, reproduced, edited or processed for any other purpose, nor otherwise transmitted, published or made available to a third party without the manufacturer's express written consent.

Subject to technical modification without prior notice.

© KSB SE & Co. KGaA, Frankenthal 16/02/2018

Contents

1	Supplementary Operating Manual	4
1.1	General.....	4
1.2	Operating data.....	4
1.3	Removing the mechanical seal	4
1.3.1	Removing a cartridge mechanical seal of the 4CP seal series	4
1.4	Installing the mechanical seal.....	5
1.4.1	Installing a cartridge mechanical seal of the 4CP seal series.....	5
1.5	General assembly drawings with list of components.....	6
1.5.1	4CP cartridge mechanical seal.....	6

1 Supplementary Operating Manual

1.1 General

This supplementary operating manual accompanies the installation/operating manual. All information contained in the installation/operating manual must be observed.

Table 1: Relevant operating manuals

Type series	Reference number of the installation/operating manual
MegaCPK	2731.8

1.2 Operating data

Table 2: Operating properties

Characteristic		Value			
Cartridge seal		C033M1-4CP	C043M1-4CP	C053M1-4CP	C065M1-4CP
Pump		MegaCPK	MegaCPK	MegaCPK	MegaCPK
Bearing bracket		CS40	CS50	CS60	CS80
Maximum temperature	T [°C]	≤ 150	≤ 150	≤ 150	≤ 150
Maximum dynamic pressure	p [bar]	25	25	25	25
Maximum static pressure	p [bar]	37,5	37,5	37,5	37,5
Maximum speed	n [rpm]	3500	3500	3500	1750
Axial displacement	[mm]	± 1,5	± 1,5	± 1,5	± 1,5

1.3 Removing the mechanical seal

1.3.1 Removing a cartridge mechanical seal of the 4CP seal series

The rules of sound engineering practice and the pump manufacturer's general provisions apply. Tidiness and cleanliness are essential for proper execution of the installation work.

- ✓ The operating manual for the pump is available.
- ✓ The back pull-out unit of the pump has been placed in a clean and level assembly area.
- ✓ The impeller and keys have been removed from the pump shaft.
 1. Undo hexagon head bolts 901. Engage assembly fixtures 96-3 in the groove of shaft sleeve 523. Lock them in this position with hexagon head bolt 901 at seal cover 471.
 2. Undo grub screws 904.
 3. Evenly loosen nuts 920.02. Remove the nuts together with discs 550.01 from studs 902.02.
 4. Unscrew the casing cover from the lantern. Carefully lift it off.
 5. Carefully and evenly pull the cartridge mechanical seal including the shaft protecting sleeve off the shaft.
 6. Remove the shaft protecting sleeve from the mechanical seal.

Further dismantling of the mechanical seal is carried out at KSB.

1.4 Installing the mechanical seal

1.4.1 Installing a cartridge mechanical seal of the 4CP seal series

	CAUTION
	<p>Use of grease or other permanent lubricants</p> <p>Torque transmission impeded/overheating of and damage to the pump!</p> <ul style="list-style-type: none"> ▷ Do not use grease or other permanent lubricants. Use soft soap to reduce friction. ▷ Do not coat seal faces with grease or oil.

- ✓ The operating manual for the pump is on hand.
- ✓ Install the mechanical seal as shown in the installation drawing.
- ✓ The back pull-out unit of the pump has been placed in a clean and level assembly area.
- ✓ The original 4CP cartridge mechanical seal is fully assembled and undamaged.
 1. O-ring 412.54 is fitted in the mechanical seal. A suitable lubricant has been applied to the O-ring.
 2. Joint ring 411 fully abuts seal cover 471.
 3. Carefully slide the cartridge mechanical seal onto the shaft protecting sleeve from the chamfered side.
 4. Slide the assembly consisting of the cartridge mechanical seal and shaft protecting sleeve onto the pump shaft.
 5. Carefully mount the casing cover on the lantern / bearing bracket. Align these components and bolt them together.
 6. Carefully mount the impeller. Fasten it with the impeller nut.
 7. Slide the cartridge mechanical seal in the direction of the pump cover until seal cover 471 with joint ring 411 abuts the casing cover.
 8. Evenly fasten the seal at the pump cover with studs 902.02, discs 550.01 and nuts 920.02. Tighten the screwed connections crosswise in several increments.
 9. Fasten the dynamic part of the mechanical seal to the shaft protecting sleeve with grub screws 904. Tighten the grub screws in several increments. Observe the tightening torques table below.
Caution: Only use compression-type fittings once!
 10. Remove hexagon head bolts 901. Swivel assembly fixtures 96-3 to disengage them. To store the assembly fixtures fasten them with hexagon head bolts at the inner drilled holes.

Table 3: Tightening torques

Thread	Torque [Nm]
M6	8
M8	15
M10	20

1.5 General assembly drawings with list of components

1.5.1 4CP cartridge mechanical seal

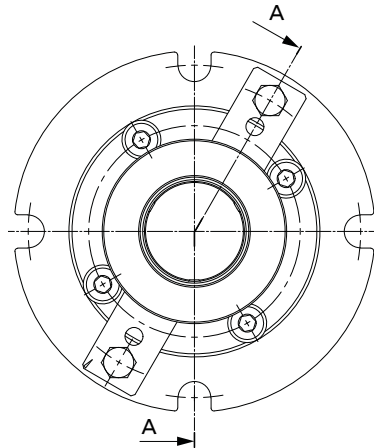

Fig. 1: Axis for the cross-section

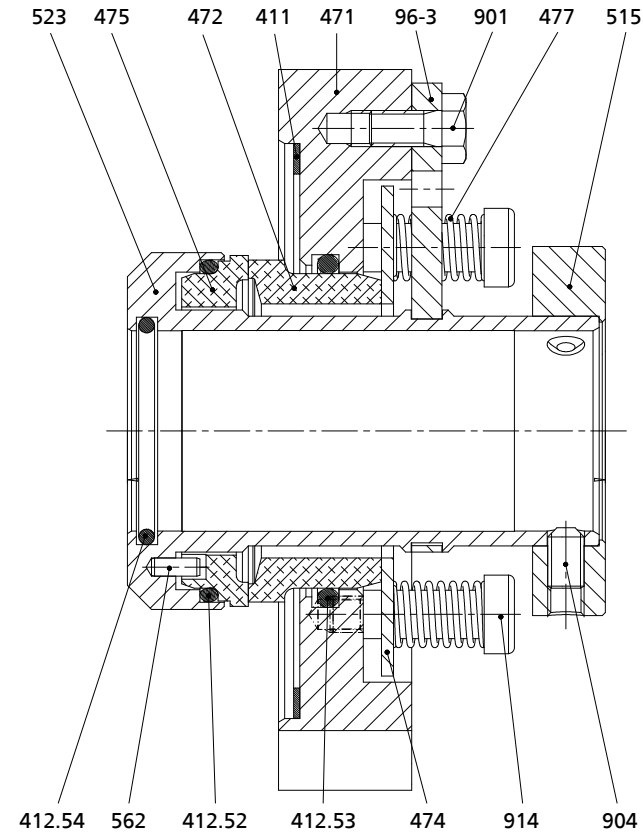

Fig. 2: Cross-section A

Table 4: List of components

Part No.	Description	Part No.	Description
96-3	Assembly fixture	477	Spring for mechanical seal
411	Joint ring	515	Taper lock ring
412.52/.53/.54	O-ring	523	Shaft sleeve
471	Seal cover	562	Parallel pin
472	Primary ring	901	Hexagon head bolt
474	Thrust ring	904	Grub screw
475	Mating ring	914	Hexagon socket head cap screw



KSB SE & Co. KGaA

Johann-Klein-Straße 9 • 67227 Frankenthal (Germany)

Tel. +49 6233 86-0

www.ksb.com